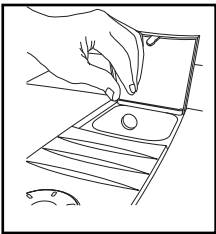

ommend cleaning the machine as described below within the next few days. To re-order tablets see chapter 15 below.

Important: Once the cleaning program has started do not interrupt the procedure.

CLEAN / READY

1. Push **Rinse Button**. The display shows **EMPTY TRAY**
Attention: If the tray and the used coffee container are already empty, you still need to remove the tray for approx. 20 seconds and then replace it.
2. Make sure that the water container is at least half full. Remove and empty the tray and the used coffee container and replace. The display shows **PRESS RINSE** and the rinse button is illuminated.
3. Place a container (at least 20 oz.) underneath the coffee spouts and push the **Rinse Button**.
4. The display shows **CLEANING**. The machine pumps one or two short cycles of water through the coffee spout. Then the display shows **ADD TABLET**.
5. Open the ground coffee funnel lid and drop one white tablet into the opening. Close the lid. The display shows **PRESS RINSE**.
6. Push the **Rinse Button** again, and the cleaning program continues. The display shows **CLEANING**. The machine starts the automatic cleaning program by dispensing water in intervals into the container underneath the coffee spout. The program stops automatically and the display shows **EMPTY TRAY**.
7. Remove the container and then the drawer and tray.
8. Empty drawer and ground coffee container and replace.
9. The display shows **READY**. The machine will automatically remind you after the next 200 cups of coffee to repeat this cycle.

14. DECALCIFYING / DE-SCALE READY

The machine has an integrated decalcifying program. This program takes about 40 minutes. When the display shows **DE-SCALE / READY** it is time to decalcify the machine. The Rinse button is illuminated. You can still make coffee. However, it is highly recommended decalcifying the machine within the next 3 to 4 days.

Important: CLEARYL BLUE FILTER: If you use the filter and the display shows **DE-SCALE / READY**, then your filter function was not activated. Follow the instructions in chapter 11 above.

Important: Do not interrupt the decalcifying program.

DECALCIFYING AGENT: Only use our special decalcifying tablets Model #66281, see chapter 15 below.

CAUTION: Never use vinegar or any other decalcifying agent. This might damage internal parts of the machine.

CAUTION: Immediately remove any splashes or drops of the decalcifying solution from sensitive surfaces, such as natural stone or wood. Always wait until the decalcifying solution in the water tank has been used up. Do not fill additional decalcifying solution into the water tank.

DE-SCALE READY and the Rinse button is illuminated.

1. Push the **Rinse Button**, display shows **EMPTY TRAY**.
Attention: If the tray and the used coffee container are already empty, you still need to remove the tray for approx. 20 seconds and then replace it. **AGENT IN TANK**.

2. Empty the Water Tank. The Clearyl filter should not be in the water tank.
3. Remove the frothXpress or the Dual Frother Plus.
4. Dissolve 3 of the large square decalcifying tablets in a container with 20 oz. of water (0.6 liters) and pour the solution into the water tank.
5. Replace water tank.
6. Place a container (at least 20 oz.) under the steam nozzle.
7. Push the **Rinse Button**. The display shows **DE-SCALING**. During this operation, the Rinse button blinks.
8. After approx. 15 minutes the action stops and the display shows **EMPTY TRAY**.
9. Remove the container and then the drawer and tray.
10. Empty the drawer and the ground coffee container. Then replace. **FILL WATER TANK**.
11. Remove the water tank, rinse and fill with up to 18 oz. of fresh cold water and replace. **PRESS RINSE**.
12. Place the container under the steam nozzle and press the **Rinse Button**.
13. The J6 pumps the fresh water through the system. During this operation, the Rinse button blinks.
14. When the display shows **EMPTY TRAY**, remove the container and then the drawer and tray.
15. Empty the drawer and the ground coffee container.
16. Replace the Dual Frother Plus or the frothXpress. **HEATING. READY**.

The machine is ready to make coffee again.

The machine will automatically remind you when it's time to decalcify again.

15) SUPPLIES can be ordered through:

- Customer Service, Mail Order Form or www.cappresso.com
- Clearyl Blue Water Filter Cartridge: #67879
 - Cleaning Tablets: #62205
 - Decalcifying Tablets: #61848

CAPRESSO CUSTOMER SERVICE:

1-800-220-5701 M-F 9AM - 9PM; Sat. 9AM - 5PM EST
FAX: 201-767-9684; email: contact@jura-cappresso.com

Impressa J6 Quick Reference Guide

This Guide does not replace the Operating Instructions. For details and cautions you must read all instructions. We highly recommend watching the instructional video.

Traces of Coffee Grounds in New Machine?
This is normal! Grinder was tested during assembly with beans. Despite cleaning, traces of ground coffee may be found.

RED TEXT represents display text.

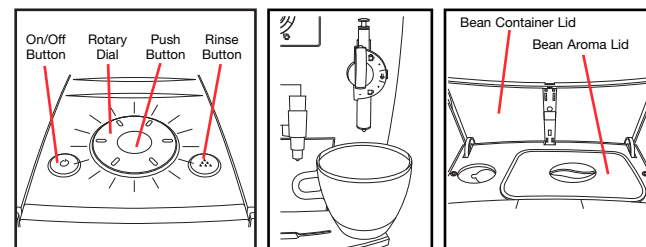

Important: You can only brew coffee when display shows **READY**.

Important: You can always stop the flow of coffee, hot water or steam by pushing any of the beverage buttons or the button in the Rotary Dial.

1) FIRST TIME EVER PREPARATION

Do not install Clearyl Blue Filter now.

1. Place machine on a flat water/steam/heat-resistant surface. Move the dual coffee spouts up and down and in and out.
2. Plug in machine and turn the **Main Power Switch** on (right side of machine next to the power cord). The On/Off button on top of the machine illuminates.
3. Push the **On/Off Button** on top of machine to turn the machine on. The LED display turns on.
4. **FILL WATER TANK**. Remove water tank (left side) and fill with fresh water.
5. **PRESS RINSE**. Place a cup under the frother and push the **Rinse Button**. **SYSTEM FILLING**.
6. **HEATING**. Then **PRESS RINSE**. Place a cup under the coffee spouts and push the **Rinse Button**.
7. **FILL BEANS**. Fill beans into the bean container. **READY**.
8. Place a large cup underneath the coffee spouts and push the **2-Cup Espresso Button**. If the machine still says **FILL BEANS**, push the **2-Cup Espresso Button** again.
9. Discard the first two cups of coffee. **READY**

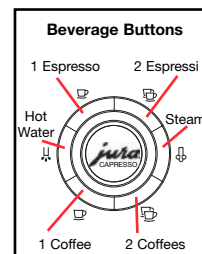

2) DAILY PREPARATION

1. Fill fresh water in tank and check bean container.
2. Push **On/Off Button**. **HEATING. PRESS RINSE**. Place a cup under the coffee spouts and push the **Rinse Button**. **RINSING. READY**.

3) PRE-WARMING CUPS / HOTTER COFFEE

- Place cup under frother. Push the **Hot Water Button**.
 - Let 2 to 3 oz. of water pre-warm the cup. Discard.
- For hotter coffee see Operating Instructions, pg. 14-15.

4) COFFEE AND ESPRESSO

Four pre-set coffee buttons: 1 ESPRESSO, 2 ESPRESSI, 1 COFFEE, 2 COFFEES. These buttons are pre-set for strength (four settings), cup size (1 to 8 oz. per cup) and temperature (HIGH, NORMAL). For details see Operating Instructions page 12, Factory Settings.

READY

- Place your pre-warmed cup(s) under the coffee spouts.
- Push one of the coffee buttons. The J6 will grind and brew the coffee and return to **READY**.

5) OVERRIDING STRENGTHS AND VOLUME

Just before pushing one of the coffee buttons you can override the strength by turning the **Rotary Dial**. The display shows **MILD, NORMAL, STRONG, XSTRONG**. The 2-cup buttons always brew in **XSTRONG**. Now push one of the coffee buttons. Turning the dial during brewing lets you override the cup size as shown in the display. Cup size for 2-cup buttons is shown **per cup!**

Chapter 17.2, pg. 24 explains how to re-program all buttons.

6) CAPPUCCINO AND LATTE / FROTHXPRESS SYSTEM

The J6 comes with two different frothing systems: The frothXpress (attached) and Dual Frother Plus (in storage compartment).

- Remove small red cap of the frothXpress. Insert black tip of flexible hose (Welcome Pack) and insert the other end into your cold milk container (pg. 6, Fig.15).
- Place your cup underneath the frothXpress.

Frothing and steaming milk for CAPPUCCINO:

- Position the DIAL between 12 and 2 o'clock.

Steaming milk for LATTE (no or very little froth):

- Position the DIAL between 4 and 6 o'clock.

- Push the **Steam Button**. **HEATING**. After a few seconds. **READY**.

- Push the **Steam Button** again. **STEAM**.

The J6 siphons the cold milk, heats and froths it directly into your cup. After 20 seconds it will stop automatically. During frothing/steaming you can change the steam

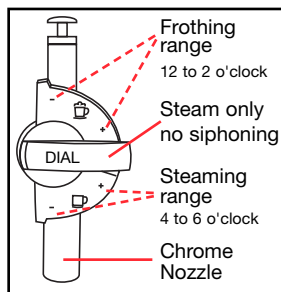

duration by turning the Rotary Dial from 3 to 120 seconds. When steaming stops you can push the steam button again to add more frothed milk or to prepare the next cup with frothed milk.

- Move the cup(s) underneath the coffee spouts and push the 1-cup or 2-cup **Espresso Button** to add the espresso.

Using the Dual Frother (see Operating Instructions, pg. 19)

7) HOTTER MILK

The milk is hotter in the 2 and 4 o'clock position than in the 12 and 6 o'clock position. If you need hotter milk:

- After frothing/steaming has stopped, turn the DIAL of the frothXpress to the 3 o'clock position (steam only). This will prevent any additional milk from entering your cup.
- Raise the cup with the frothed milk so that the chrome nozzle of the frothXpress is immersed.
- Push the **Steam Button** again. **STEAM**. Steam will increase your milk temperature. Push the **Steam Button** to stop.

Warning: if you steam too long, the milk might boil.

8) HOT CHOCOLATE AND CAFE MOCHA

Add chocolate syrup to your cold milk and stir well. Then follow the steps in chapter 6, above. Adding a shot or two of espresso creates a Café Mocha.

9) TEA, CAFE AMERICANO, PRE-WARMING CUPS

Place a cup underneath the frother and push the **Hot Water Button**. Hot water will be released. Use to pre-warm your cups and to make tea. Café Americano: one or two shots espresso plus 2 to 4 oz. of hot water.

10) CLEANING THE FROTHXPRESS

Quick Rinse (within an hour after using the frothXpress)

READY

- Place a cup underneath the frothXpress
- Place a cup with cold water next to the J6 and insert the other end of the milk hose.
- Push the **Steam Button**. **HEATING. READY**.
- Push the **Steam Button** again. Steam/water will clean the frothXpress.
- After a few seconds push any beverage button to stop.

Thorough Cleaning

Milk fat can build up inside the frothXpress. The J6 comes with a bottle of milk fat dissolver (Cappuccino Cleaner). This is fast, thorough, fool proof and easy.

- Remove the frothXpress from the steam nozzle and take it apart.
- Place all parts including the hose in a cup with water and add just one capful (15ml / 1/2 oz.) of the concentrate. Let sit for ten minutes or overnight.

- Rinse all parts under fresh water and assemble.

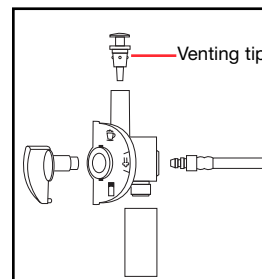

11) INSTALLING /ACTIVATING CLEARLY BLUE FILTER

Important: Never install the filter before or during "First Time Ever Preparation".

READY.

1. Push and hold the **Rotary Dial** until the display shows **RINSE**.
2. Turn the **Rotary Dial** until display shows **FILTER -**.
3. Push the **Dial**. The display shows **NO -**.
4. Turn the **Dial**. The display shows **YES**. Push the dial to confirm. **OK**.
5. **INSERT RINSE**. The Rinse button illuminates.
6. Unpack the Clearly Blue filter and rinse under water.

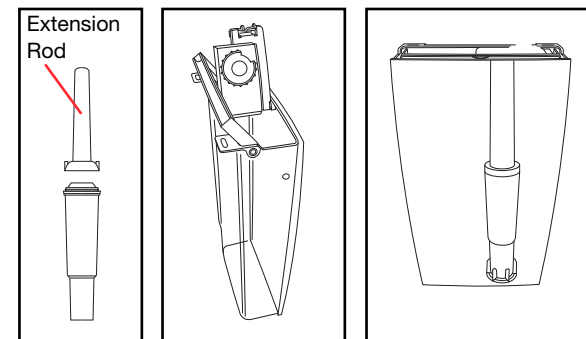

7. Attach **Extension Rod** to filter.
8. Remove the water tank, make sure it is empty.
9. Pull-up the filter holder and insert the filter with the tapered end down into the water container.
10. Make sure it fits securely inside the fins.
11. Close filter holder.
12. Fill water tank with fresh cold water and replace.
13. Place a 20 oz. container under the steam nozzle.
14. Press the **Rinse Button**. **FILTER RINSING**.
15. Cold water is pushed through the filter and the frother for 90 sec. **HEATING. READY**.

The filter is now activated. The J6 will automatically remind you when to replace the filter.

12) REPLACING THE CLEARLY BLUE FILTER

When display shows **READY FILTER** it's time to replace the filter.

- Push the Rinse button. **CHANGE**.
- Remove the water tank. Remove the old filter and detach the extension rod.
- Continue with steps 6 through 15 above.

13) CLEANING WITH SPECIAL TABLET

This cleaning cycle removes coffee oils inside the machine. This message will appear after 200 cups of coffee: **CLEAN / READY**. Takes only 15 minutes!

Important: Only use the special white round cleaning tablet. The J6 comes with a pack of two tablets. You can continue to make coffee, however we highly rec-